

ANDY
WEIR



PROJECT

HAIL
MARY

PROJECT HAIL MARY

A NOVEL

ANDY WEIR



BALLANTINE BOOKS
NEW YORK

Project Hail Mary is a work of fiction. Names, characters, places, and incidents are the products of the author's imagination or are used fictitiously. Any resemblance to actual events, locales, or persons, living or dead, is entirely coincidental.

Copyright © 2021 by Andy Weir

All rights reserved.

Published in the United States by Ballantine Books, an imprint of Random House, a division of Penguin Random House LLC, New York.

BALLANTINE and the HOUSE colophon are registered trademarks of Penguin Random House LLC.

Library of Congress Cataloging-in-Publication Data

Names: Weir, Andy, author.

Title: Project Hail Mary: a novel / Andy Weir.

Description: First edition. | New York: Ballantine Books, [2021]

Identifiers: LCCN 2020015821 (print) | LCCN 2020015822 (ebook) | ISBN 9780593135204 (hardback; acid-free paper) | ISBN 9780593135211 (ebook); international edition: ISBN 978059335527-5

Subjects: GSAFD: Science fiction.

Classification: LCC PS3623.E4324494 P76 2021 (print) | LCC PS3623.E4324494 (ebook) | DDC 813/.6—dc23

LC record available at <https://lcn.loc.gov/2020015821>

LC ebook record available at <https://lcn.loc.gov/2020015822>

Ebook ISBN 9780593135211

Title page image: iStock/Roman Kulinskiy

Rocket diagrams: © David Lindroth Inc.

randomhousebooks.com

Book design by Caroline Cunningham, adapted for ebook

Cover design: Will Staehle

ep_prh_5.6.1_c0_r0

Contents

[Cover](#)

[Title Page](#)

[Copyright](#)

[Chapter 1](#)

[Chapter 2](#)

[Chapter 3](#)

[Chapter 4](#)

[Chapter 5](#)

[Chapter 6](#)

[Chapter 7](#)

[Chapter 8](#)

[Chapter 9](#)

[Chapter 10](#)

[Chapter 11](#)

[Chapter 12](#)

[Chapter 13](#)

[Chapter 14](#)

[Chapter 15](#)

[Chapter 16](#)

[Chapter 17](#)

[Chapter 18](#)

[Chapter 19](#)

[Chapter 20](#)

[Chapter 21](#)

[Chapter 22](#)

[Chapter 23](#)

[Chapter 24](#)

[Chapter 25](#)

[Chapter 26](#)

[Chapter 27](#)

[Chapter 28](#)

[Chapter 29](#)

[Chapter \$\forall \ell\$](#)

[*Dedication*](#)

[*Acknowledgments*](#)

[*By Andy Weir*](#)

[*About the Author*](#)

THRUST CONFIGURATION

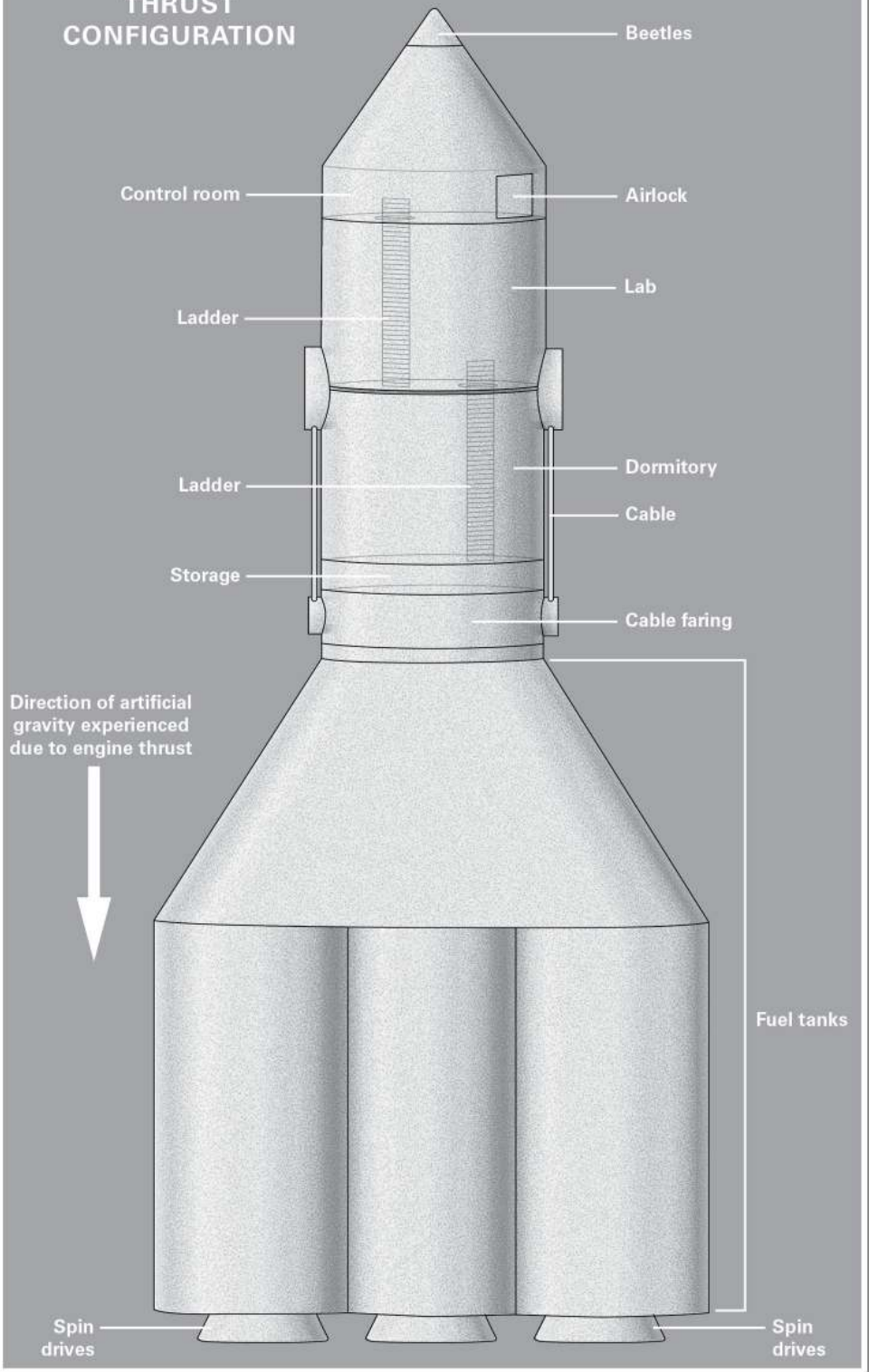

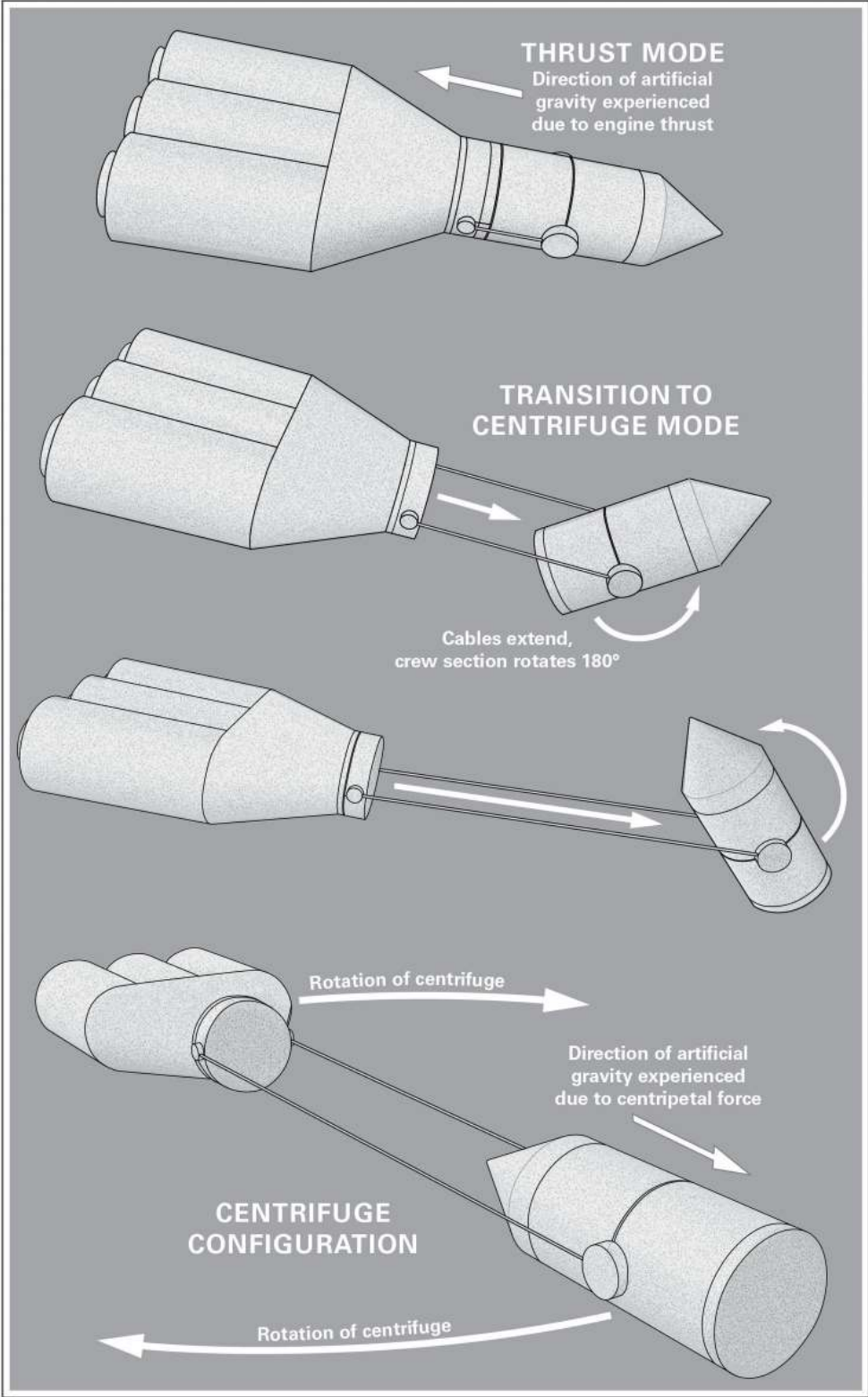

CHAPTER 1

“What’s two plus two?”

Something about the question irritates me. I’m tired. I drift back to sleep.

A few minutes pass, then I hear it again.

“What’s two plus two?”

The soft, feminine voice lacks emotion and the pronunciation is identical to the previous time she said it. It’s a computer. A computer is hassling me. I’m even more irritated now.

“Lrmln,” I say. I’m surprised. I meant to say “Leave me alone”—a completely reasonable response in my opinion—but I failed to speak.

“Incorrect,” says the computer. “What’s two plus two?”

Time for an experiment. I’ll try to say hello.

“Hllch?” I say.

“Incorrect. What’s two plus two?”

What’s going on? I want to find out, but I don’t have much to work with. I can’t see. I can’t hear anything other than the computer. I can’t even feel. No, that’s not true. I feel something. I’m lying down. I’m on something soft. A bed.

I think my eyes are closed. That’s not so bad. All I have to do is open them. I try, but nothing happens.

Why can’t I open my eyes?

Open.

Aaaand...open!

Open, dang it!

Ooh! I felt a wiggle that time. My eyelids moved. I felt it.

Open!

My eyelids creep up and blinding light sears my retinas.

“Glunn!” I say. I keep my eyes open with sheer force of will. Everything is white with shades of pain.

“Eye movement detected,” my tormenter says. “What’s two plus two?”

The whiteness lessens. My eyes are adjusting. I start to see shapes, but nothing sensible yet. Let’s see...can I move my hands? No.

Feet? Also no.

But I can move my mouth, right? I’ve been saying stuff. Not stuff that makes sense, but it’s something.

“Fffr.”

“Incorrect. What’s two plus two?”

The shapes start to make sense. I’m in a bed. It’s kind of...oval-shaped.

LED lights shine down on me. Cameras in the ceiling watch my every move. Creepy though that is, I’m much more concerned about the robot arms.

The two brushed-steel armatures hang from the ceiling. Each has an assortment of disturbingly penetration-looking tools where hands should be. Can’t say I like the look of that.

“Ffff...oooh...rrrr,” I say. Will that do?

“Incorrect. What’s two plus two?”

Dang it. I summon all my willpower and inner strength. Also, I’m starting to panic a little. Good. I use that too.

“Fffoouurr,” I finally say.

“Correct.”

Thank God. I can talk. Sort of.

I breathe a sigh of relief. Wait—I just controlled my breathing. I take another breath. On purpose. My mouth is sore. My throat is sore. But it’s *my* soreness. I have control.

I’m wearing a breathing mask. It’s tight to my face and connected to a hose that goes behind my head.

Can I get up?

No. But I can move my head a little. I look down at my body. I'm naked and connected to more tubes than I can count. There's one in each arm, one in each leg, one in my "gentlemen's equipment," and two that disappear under my thigh. I'm guessing one of them is up where the sun doesn't shine.

That can't be good.

Also, I'm covered with electrodes. The sensor-type stickers like for an EKG, but they're all over the place. Well, at least they're only on my skin instead of jammed into me.

"Wh—" I wheeze. I try again. "Where...am...I?"

"What's the cube root of eight?" the computer asks.

"Where am I?" I say again. This time it's easier.

"Incorrect. What's the cube root of eight?"

I take a deep breath and speak slowly. "Two times e to the two- i -pi."

"Incorrect. What's the cube root of eight?"

But I wasn't incorrect. I just wanted to see how smart the computer was.
Answer: not very.

"Two," I say.

"Correct."

I listen for follow-up questions, but the computer seems satisfied.

I'm tired. I drift off to sleep again.

—

I wake up. How long was I out? It must have been a while because I feel rested. I open my eyes without any effort. That's progress.

I try to move my fingers. They wiggle as instructed. All right. Now we're getting somewhere.

"Hand movement detected," says the computer. "Remain still."

"What? Why—"

The robot arms come for me. They move *fast*. Before I know it, they've removed most of the tubes from my body. I didn't feel a thing. Though my skin is kind of numb anyway.

Only three tubes remain: an IV in my arm, a tube up my butt, and a catheter. Those latter two are kind of the signature items I wanted removed, but okay.

I raise my right arm and let it fall back to the bed. I do the same for my left. They feel heavy as heck. I repeat the process a few times. My arms are muscular. That doesn't make sense. I assume I've had some massive medical problem and been in this bed for a while. Otherwise, why would they have me hooked up to all the stuff? Shouldn't there be muscle atrophy?

And shouldn't there be doctors? Or maybe the sounds of a hospital? And what's with this bed? It's not a rectangle, it's an oval and I think it's mounted to the wall instead of the floor.

"Take..." I trail off. Still kind of tired. "Take the tubes out..."

The computer doesn't respond.

I do a few more arm lifts. I wiggle my toes. I'm definitely getting better.

I tilt my ankles back and forth. They're working. I raise my knees up. My legs are well toned too. Not bodybuilder thick, but still too healthy for someone on the verge of death. I'm not sure how thick they should be, though.

I press my palms to the bed and push. My torso rises. I'm actually getting up! It takes all my strength but I soldier on. The bed rocks gently as I move. It's not a normal bed, that's for sure. As I raise my head higher up, I see the head and foot of the elliptical bed are attached to strong-looking wall mounts. It's kind of a rigid hammock. Weird.

Soon, I'm sitting on my butt tube. Not the most comfortable sensation, but when is a tube up your butt ever comfortable?

I have a better view of things now. This is no ordinary hospital room. The walls look plastic and the whole room is round. Stark-white light comes from ceiling-mounted LED lights.

There are two more hammock-like beds mounted to the walls, each with their own patient. We are arranged in a triangle and the roof-mounted Arms of Harassment are in the center of the ceiling. I guess they take care of all three of us. I can't see much of my compatriots—they've sunken into their bedding like I had.

There's no door. Just a ladder on the wall leading to...a hatch? It's round and has a wheel-handle in the center. Yeah, it's got to be some kind of hatch. Like on a submarine. Maybe the three of us have a contagious disease? Maybe this is an airtight quarantine room? There are small vents here and there on the wall and I feel a little airflow. It could be a controlled environment.

I slide one leg off over the edge of my bed, which makes it wobble. The robot arms rush toward me. I flinch, but they stop short and hover nearby. I think they're ready to grab me if I fall.

"Full-body motion detected," the computer says. "What's your name?"

"Pfft, seriously?" I ask.

"Incorrect. Attempt number two: What's your name?"

I open my mouth to answer.

"Uh..."

"Incorrect. Attempt number three: What's your name?"

Only now does it occur to me: I don't know who I am. I don't know what I do. I don't remember anything at all.

"Um," I say.

"Incorrect."

A wave of fatigue grips me. It's kind of pleasant, actually. The computer must have sedated me through the IV line.

"...waaaait..." I mumble.

The robot arms lay me gently back down to the bed.

—

I wake up again. One of the robot arms is on my face. What is it doing?!

I shudder, more shocked than anything else. The arm retracts back to its home in the ceiling. I feel my face for damage. One side has stubble and the other is smooth.

"You were shaving me?"

"Consciousness detected," the computer says. "What's your name?"

"I still don't know that."

“Incorrect. Attempt number two: What’s your name?”

I’m Caucasian, I’m male, and I speak English. Let’s play the odds. “J–John?”

“Incorrect. Attempt number three: What’s your name?”

I pull the IV out of my arm. “Bite me.”

“Incorrect.” The robot arms reach for me. I roll off the bed, which is a mistake. The other tubes are still connected.

The butt tube comes right out. Doesn’t even hurt. The still-inflated catheter yanks right out of my penis. And that *does* hurt. It’s like peeing a golf ball.

I scream and writhe on the floor.

“Physical distress,” says the computer. The arms give chase. I crawl along the floor to escape. I get under one of the other beds. The arms stop short, but they don’t give up. They wait. They’re run by a computer. It’s not like they’ll run out of patience.

I let my head fall back and gasp for breath. After a while, the pain subsides and I wipe tears from my eyes.

I have no idea what’s going on here.

“Hey!” I call out. “One of you, wake up!”

“What’s your name?” the computer asks.

“One of you *humans*, wake up, please.”

“Incorrect,” the computer says.

My crotch hurts so bad I have to laugh. It’s just so absurd. Plus, the endorphins are kicking in and making me giddy. I look back at the catheter by my bunk. I shake my head in awe. That thing went through my urethra. Wow.

And it did some damage on the way out. A little streak of blood sits on the ground. It’s just a thin red line of—

—

I sipped my coffee, popped the last fragment of toast into my mouth, and signaled the waitress for my check. I could have saved money by eating breakfast at home instead of going to a diner every morning. Probably would

have been a good idea, considering my meager salary. But I hate cooking and I love eggs and bacon.

The waitress nodded and walked over to the cash register to ring me up. But another customer came in to be seated right that moment.

I checked my watch. Just past seven A.M. No rush. I liked to get in to work by seven-twenty so I could have time to prep for the day. But I didn't actually need to be there until eight.

I pulled out my phone and checked my email.

TO: Astronomy Curiosities astrocurious@scilists.org
FROM: (Irina Petrova, PhD) ipetrova@gaoran.ru
SUBJECT: The Thin Red Line

I frowned at the screen. I thought I'd unsubscribed from that list. I left that life a long time ago. It didn't get a lot of volume, and what it did get, if memory served, was usually pretty interesting. Just a bunch of astronomers, astrophysicists, and other domain experts chatting about anything that struck them as odd.

I glanced at the waitress—the customers had a bunch of questions about the menu. Probably asking if Sally's Diner served gluten-free vegan grass clippings or something. The good people of San Francisco could be trying at times.

With nothing better to do, I read the email.

Hello, professionals. My name is Doctor Irina Petrova and I work at the Pulkovo Observatory in St. Petersburg, Russia.

I am writing to you to ask for help.

For the past two years, I have been working on a theory related to infrared emissions from nebulae. As a result, I have made detailed observations in a few specific IR bands of light. And I have found something odd—not in any nebula, but here in our own solar system.

There is a very faint, but detectable line in the solar system that emits infrared light at the 25.984 micron wavelength. It seems to be solely that wavelength with no variance.

Attached are Excel spreadsheets with my data. I have also provided a few renders of the data as a 3-D model.

You will see on the model that the line is a lopsided arc that rises straight up from the sun's North Pole for 37 million kilometers. From there, it angles sharply down and away

from the sun, toward Venus. After the arc's apex, the cloud widens like a funnel. At Venus, the arc's cross-section is as wide as the planet itself.

The infrared glow is very faint. I was only able to detect it at all because I was using extremely sensitive detection equipment while searching for IR emissions from nebulae.

But to be certain, I called in a favor from the Atacama observatory in Chile—in my opinion the best IR observatory in the world. They confirmed my findings.

There are many reasons one might see IR light in interplanetary space. It could be space dust or other particles reflecting sunlight. Or some molecular compound could be absorbing energy and re-emitting it in the infrared band. That would even explain why it's all the same wavelength.

The shape of the arc is of particular interest. My first guess was that it is a collection of particles moving along magnetic field lines. But Venus has no magnetic field to speak of. No magnetosphere, no ionosphere, nothing. What forces would make particles arc toward it? And why would they glow?

Any suggestions or theories would be welcome.

—

What the heck was that?

I remembered it all at once. It just kind of showed up in my head without warning.

I didn't learn much about myself. I live in San Francisco—I remember that. And I like breakfast. Also I used to be into astronomy but now I'm not?

Apparently my brain decided it was critical that I remember that email. Not trivial things like *my own name*.

My subconscious wants to tell me something. Seeing the line of blood must have reminded me of the "Thin Red Line" title of that email. But what's that got to do with me?

I shimmy out from under the bed and sit up against the wall. The arms angle toward me, but still can't reach.

Time to get a look at my fellow patients. I don't know who I am or why I'm here, but at least I'm not alone—aaaand they're dead.

Yes, definitely dead. The one closest to me was a woman, I think. At least, she had long hair. Other than that, she's mostly a mummy. Desiccated skin draped over bones. There's no smell. Nothing is actively rotting. She must have died a long time ago.

The person in the other bed was a man. I think he's been dead even longer. His skin is not only dry and leathery but also crumbling away.

Okay. So I'm here with two dead people. I should be disgusted and horrified, but I'm not. They're so far gone they don't even look human. They look like Halloween decorations. I hope I wasn't close friends with either of them. Or, if I was, I hope I don't remember it.

Dead people is a concern, but I'm more concerned that they've been here so long. Even a quarantine area would remove dead people, wouldn't they? Whatever's wrong must be pretty darn bad.

I get to my feet. It's slow and it takes a lot of effort. I steady myself at the edge of Ms. Mummy's bed. It wobbles and I wobble with it, but I stay upright.

The robot arms make a play for me, but I flatten myself against the wall again.

I'm pretty sure I was in a coma. Yeah. The more I think of it, I was definitely in a coma.

I don't know how long I've been here, but if I was put here at the same time as my roommates it's been a while. I rub my half-shaved face. Those arms are designed to manage long-term unconsciousness. More evidence I was in a coma.

Maybe I can get to that hatch?

I take a step. Then another. Then I sink to the floor. It's just too much for me. I have to rest.

Why am I so weak when I have these well-toned muscles? And if I was in a coma, why do I even have muscles? I should be a withered, spindly mess right now, not beach-bod buff.

I have no idea what my endgame is. What should I do? Am I really sick? I mean, I feel like crud of course, but I don't feel "sick." I'm not nauseated. I don't have a headache. I don't think I have a fever. If I don't have a disease, why was I in a coma? Physical injury?

I feel around my head. No lumps or scars or bandages. The rest of my body seems pretty solid too. Better than solid. I'm ripped.

I want to nod off but I resist it.

Time to take another stab at this. I push myself back up. It's like weightlifting. But it's a little easier this time. I'm recovering more and more (I hope).

I shuffle along the wall, using my back for support as much as my feet. The arms constantly reach for me but I stay out of range.

I pant and wheeze. I feel like I've run a marathon. Maybe I have a lung infection? Maybe I'm in isolation for my own protection?

I finally make it to the ladder. I stumble forward and grab one of the rungs. I'm just so weak. How am I going to climb a 10-foot ladder?

Ten-foot ladder.

I think in imperial units. That's a clue. I'm probably an American. Or English. Or maybe Canadian. Canadians use feet and inches for short distances.

I ask myself: How far is it from L.A. to New York? My gut answer: 3,000 miles. A Canadian would have used kilometers. So I'm English or American. Or I'm from Liberia.

I know Liberia uses imperial units but I don't know my own name. That's irritating.

I take a deep breath. I hang on to the ladder with both hands and put my foot on the bottom rung. I pull myself up. It's a shaky process, but I get it done. Both feet are on the lower rung now. I reach up and grab the next rung. Okay, making progress. I feel like my whole body is made of lead—everything is so much effort. I try to pull myself up, but my hand just isn't strong enough.

I fall backward off the ladder. This is going to hurt.

It doesn't hurt. The robot arms catch me before I hit the ground because I fell into grabbing range. They don't miss a beat. They return me to bed and settle me in like a mother putting her child to sleep.

You know what? This is fine. I'm really tired at this point and lying down kind of works for me. The gentle rocking of the bed is comforting. Something bugs me about how I fell off the ladder. I replay it in my head. I can't put my finger on it, but there's just a... "wrongness" to it.

Hmm.

I drift off.

—

“Eat.”

There’s a toothpaste tube on my chest.

“Huh?”

“Eat,” the computer says again.

I lift the tube. It’s white with black text that reads DAY 1—MEAL 1.

“The heck is this?” I say.

“Eat.”

I unscrew the cap and smell something savory. My mouth waters at the prospect. Only now do I realize how hungry I am. I squeeze the tube and disgusting-looking brown sludge comes out.

“Eat.”

Who am I to question a creepy robot-armed computer overlord? I cautiously lick the substance.

Oh my God it’s good! It’s so good! It’s like thick gravy but not too rich. I squeeze more straight into my mouth and savor it. I swear it’s better than sex.

I know what’s going on here. They say hunger is the greatest seasoning. When you’re starving, your brain rewards you handsomely for finally eating. *Good job, it says, we get to not die for a while!*

The pieces fall into place. If I was in a coma for a long time, I must have been getting fed. I didn’t have an abdominal tube when I woke up, so it was probably feeding me with an NG tube running down my esophagus. It’s the least-intrusive way to feed a patient who can’t eat but has no digestion issues. Plus, it keeps the digestive system active and healthy. And it explains why the tube wasn’t around when I woke up. If possible, you should remove an NG tube while the patient is still unconscious.

Why do I know that? Am I a doctor?

I squeeze another shot of gravy-goo into my mouth. Still delicious. I gobble it down. Soon the tube is empty. I hold it up. “More of this!”

“Meal complete.”

“I’m still hungry! Give me another tube!”

“Food allotment for this meal has been met.”

It makes sense. My digestive system is getting used to semi-solid food right now. Best to take it easy. If I eat as much as I want I’ll probably get sick. The computer is doing the right thing.

“Give me more food!” No one cares about the right thing when they’re hungry.

“Food allotment for this meal has been met.”

“Bah.”

Still, I feel a ton better than I did before. The food energized me on the spot, plus I’ve had more rest.

I roll out of bed, ready to make a break for the wall, but the arms don’t chase me. I guess I’m allowed out of bed now that I’ve proven I can eat.

I look down at my naked body. This just doesn’t feel right. I know the only other people around are dead, but still.

“Can I have some clothes?”

The computer says nothing.

“Fine. Be that way.”

I pull the sheet off the bed and wrap it around my torso a couple of times. I pull one corner over my shoulder from behind my back and tie it to another from the front. Instant toga.

“Self-ambulation detected,” says the computer. “What’s your name?”

“I am Emperor Comatose. Kneel before me.”

“Incorrect.”

Time to see what’s up that ladder.

I’m a little unsteady, but I start walking across the room. This is a victory in itself—I don’t need wobbly beds or walls to cling to. I’m on my own two feet.

I make it to the ladder and grab hold. I don’t *need* something to hang on to, but it sure makes life easier. The hatch above looks pretty darn solid. I assume it’s airtight. And there’s every chance it’s locked. But I have to at least try.

I climb up one rung. Tough, but doable. Another rung. Okay, I have the hang of this. Slow and steady.

I make it to the hatch. I hang on to the ladder with one hand and turn the hatch's circular crank with the other. It actually turns!

“Holy moly!” I say.

“Holy moly”? Is that my go-to expression of surprise? I mean, it's okay, I guess. I would have expected something a little less 1950s. What kind of weirdo am I?

I turn the crank three full rotations and hear a click. The hatch tilts downward and I get out of the way. It falls open, suspended by its hefty hinge. I'm free!

Sort of.

Beyond the hatch, there's just darkness. A little intimidating, but at least it's progress.

I reach into the new room and pull myself up to the floor. Lights click on as soon as I enter. Presumably the computer's doing.

The room looks to be the same size and shape as the one I left—another round room.

One large table—a lab table from the look of it—is mounted to the floor. Three lab stools are mounted nearby. All around the walls are pieces of lab equipment. All of it mounted to tables or benches that are bolted to the floor. It's like the room is ready for a catastrophic earthquake.

A ladder along the wall leads to another hatch in the ceiling.

I'm in a well-stocked laboratory. Since when do isolation wards let patients into the lab? And this doesn't look like a medical lab, anyway. What the fudge is going on?!

Fudge? Seriously? Maybe I have young kids. Or I'm deeply religious.

I stand to get a better look at things.

The lab has smaller equipment bolted to the table. I see an 8000x microscope, an autoclave, a bank of test tubes, sets of supply drawers, a sample fridge, a furnace, pipettes—wait a minute. Why do I know all those terms?